

Video Solution on Website:-

<https://physicsaholics.com/home/courseDetails/80>

Video Solution on YouTube:-

<https://youtu.be/pDSah-0wgk>

Written Solution on Website:-

<https://physicsaholics.com/note/notesDetails/17>

- Q 1. If V is velocity of center of mass of a rolling body then velocity of lowest point of that body is
 (a) $\sqrt{2}V$ (b) V
 (c) $2V$ (d) zero
- Q 2. A solid sphere has a radius of 0.200 m and a mass of 150.0 kg. How much work is required to get the sphere rolling with an angular speed of 50.0 rad/s on a horizontal surface? assume that the sphere starts from rest and rolls without slipping
 (a) 7500 J (b) 10500 J
 (c) 2500 J (d) 3000 J
- Q 3. A solid sphere of mass m and radius R roll without slipping on a horizontal surface such that $V_{cm} = v_0$
 (a) The kinetic energy of rotation is $\frac{1}{5}mv_0^2$
 (b) The total kinetic energy is $\frac{7}{10}mv_0^2$
 (c) The mechanical energy (assume the ground as reference) is $mgR + \frac{7}{10}mv_0^2$
 (d) All options are correct
- Q 4. The disc of radius r is confined to roll without slipping at A and B. If the plates have the velocities shown, then
 (a) Angular velocity of the disc is $\frac{2v}{r}$
 (b) Linear velocity $v_0 = v$
 (c) Angular velocity of the disc is $\frac{3v}{2r}$
 (d) Both A & B
- Q 5. The disc of the radius R is confined to roll without slipping at A and B. If the plates having the velocities as shown, determine the angular velocity of disc

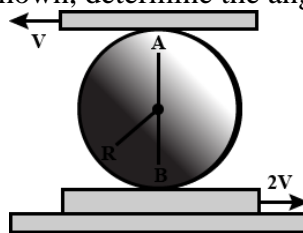

- (a) $\frac{3v}{2r}$ clockwise (b) $\frac{2v}{3r}$ clockwise
 (c) $\frac{3v}{2r}$ anti-clockwise (d) $\frac{2v}{3r}$ anti-clockwise

Q 6. Instantaneous center of the rotation of disc is located at (o is centre of disc)

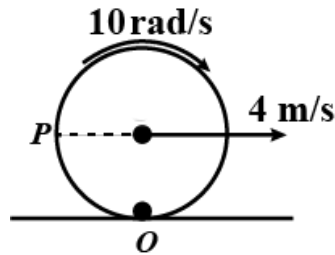

- (a) 0.2 m below O
- (b) 0.2 m above O
- (c) 0.6 m above O
- (d) 0.4 m below O

Q 7. A string of negligible thickness is wrapped several times around a cylinder kept on a rough horizontal surface. A man standing at a distance l from the cylinder holds one end of the string and pulls the cylinder towards him (figure). There is no slipping anywhere. The length of the string passed through the hand of the man while the cylinder reaches his hands is –

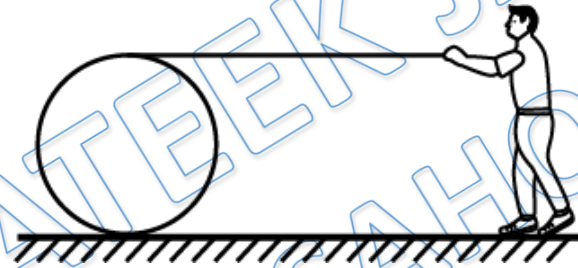

- (a) l
- (b) $2l$
- (c) $3l$
- (d) $4l$

Q 8. Find the instantaneous axis of rotation of a rod of length " ℓ " when its end A moves with velocity $\vec{v} = v\hat{i}$ and the rod rotates with an angular velocity $\vec{\omega} = -\frac{v}{2\ell}\hat{k}$

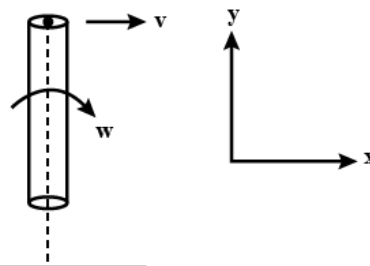

- (a) 2ℓ from A
- (b) $\frac{2\ell}{3}$ from A
- (c) $\frac{3\ell}{2}$ from A
- (d) ℓ from A

Q 9. A solid sphere is rolling on a surface as shown in figure, with a translational velocity v m s^{-1} . If it is to climb the inclined surface continuing to roll without slipping, then minimum velocity for this to happen is

- (a) $\sqrt{2gh}$
- (b) $\sqrt{\frac{7}{5}gh}$



(c) $\sqrt{\frac{7}{2}gh}$

(d) $\sqrt{\frac{10}{7}gh}$

Q 10. A Disc is nonuniformly rolling on ground, acceleration of its bottommost point is

- (a) zero
- (b) Along velocity of centre
- (c) In vertically upward direction
- (d) None of these

Q 11. A disc of radius 1 m is rolling on ground. Distance travelled by its centre in 7 rounds is

- (a) 7 m
- (b) 22 m
- (c) 44 m
- (d) It is not possible to find distance as velocity of centre of disc is not known.

Q 12. A man is pulling a string with speed v , which is wrapped on a spool. Speed of centre of spool is(if spool is rolling on ground)

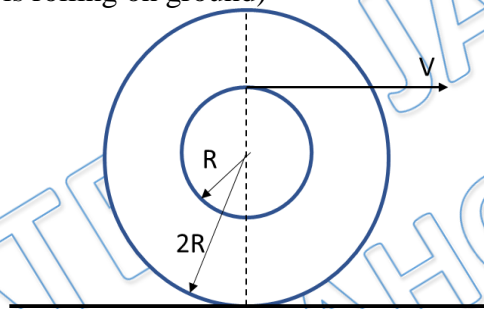

- (a) v
- (b) $2v$
- (c) $\frac{2v}{3}$
- (d) $3v$



Answer Key

Q.1 d	Q.2 b	Q.3 d	Q.4 d	Q.5 c
Q.6 d	Q.7 b	Q.8 a	Q.9 d	Q.10 c
Q.11 c	Q.12 c			

PRATEEK JAIN
PHYSICSAHOLICS

PLUS

ICONIC **

- ✓ India's Best Educators
- ✓ Interactive Live Classes
- ✓ Structured Courses & PDFs
- ✓ Live Tests & Quizzes
- ✗ Personal Coach
- ✗ Study Planner

24 months ₹2,333/mo >
No cost EMI ₹56,000

18 months ₹2,625/mo >
No cost EMI ₹47,250

12 months ₹3,208/mo >
No cost EMI ₹38,500

6 months ₹4,667/mo >
No cost EMI ₹28,000

To be paid as a one-time payment

View all plans



Add a referral code

APPLY

PHYSICSLIVE

PLUS

ICONIC **

- ✓ India's Best Educators
- ✓ Interactive Live Classes
- ✓ Structured Courses & PDFs
- ✓ Live Tests & Quizzes
- ✗ Personal Coach
- ✗ Study Planner

24 months ₹2,100/mo >
No cost EMI +10% OFF ₹50,400

18 months ₹2,363/mo >
No cost EMI +10% OFF ₹42,525

12 months ₹2,888/mo >
No cost EMI +10% OFF ₹34,650

6 months ₹4,200/mo >
No cost EMI +10% OFF ₹25,200

To be paid as a one-time payment

View all plans



Awesome! PHYSICSLIVE code applied



Use code **PHYSICSLIVE** to get 10% OFF on Unacademy PLUS.

Written Solution

**DPP- 6 Rotation: Kinematics of Combined
Translation & Rotation ,Kinematics of Rolling
Motion, Kinetic Energy in Rolling**

By Physicsaholics Team

Q.1) If V is velocity of center of mass of a body rolling on ground then velocity of lowest point of that body is

(a) $\sqrt{2}V$

(b) V

(c) $2V$

~~(d) zero~~

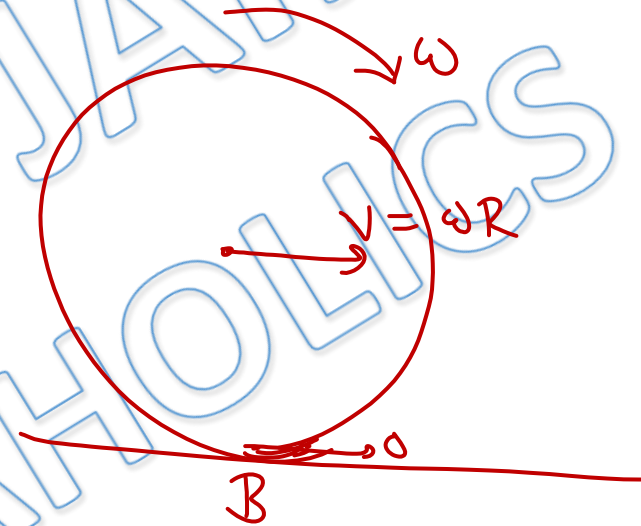

$$\begin{aligned}V_B &= V - \omega R \\ &= 0\end{aligned}$$

Q.2) A solid sphere has a radius of 0.200 m and a mass of 150.0 kg. How much work is required to get the sphere rolling with an angular speed of 50.0 rad/s on a horizontal surface? assume that the sphere starts from rest and rolls without slipping

(a) 7500 J

(b) 10500 J

(c) 2500 J

(d) 3000 J

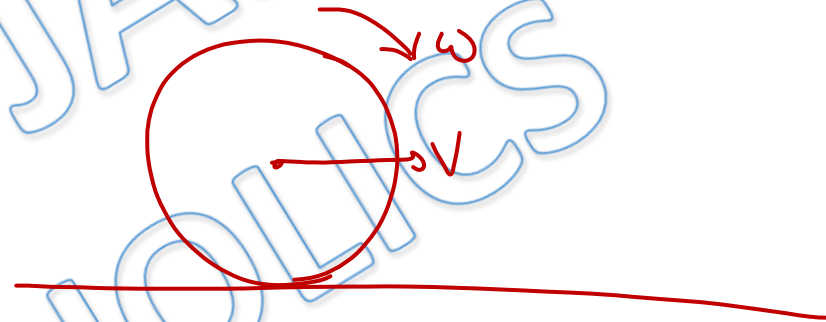

$$KE = \frac{7}{10} \times 150 \times 4 \times 10^2 \times 2500$$

$$= 10500 \text{ J}$$

$$KE = \frac{1}{2} m v_{cm}^2 + \frac{1}{2} I_{cm} \omega^2$$

$$= \frac{1}{2} \times m v^2 + \frac{1}{2} \left(\frac{2}{5} m R^2 \right) \frac{v^2}{R^2}$$

$$= \frac{7}{10} m v^2$$

$$= \frac{7}{10} m R^2 \omega^2$$

Q.3) A solid sphere of mass m and radius R roll without slipping on a horizontal surface such that $V_{cm} = v_0$

$$\begin{aligned} RKE &= \frac{1}{2} I_{cm} \omega^2 = \frac{1}{2} \left(\frac{2}{5} m R^2 \right) \omega^2 \\ &= \frac{1}{5} m v_0^2 \end{aligned}$$

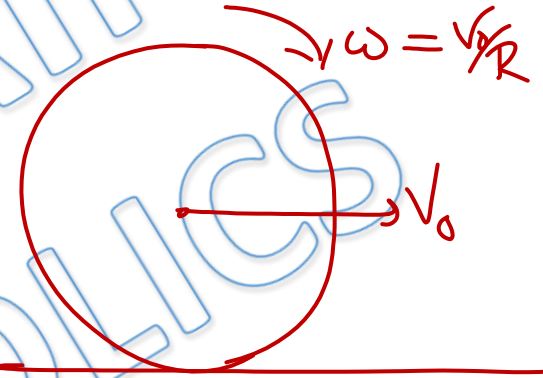

(a) The kinetic energy of rotation is $\frac{1}{5} m v_0^2$

(b) The total kinetic energy is $\frac{7}{10} m v_0^2$

(c) The mechanical energy (assume the ground as reference) is $mgR + \frac{7}{10} m v_0^2$

(d) All options are correct

$$TKE = \frac{1}{2} m v_0^2 + \frac{1}{5} m v_0^2 = \frac{7}{10} m v_0^2$$

Q.4) The disc of radius r is confined to roll without slipping at A and B. If the plates have the velocities shown, then

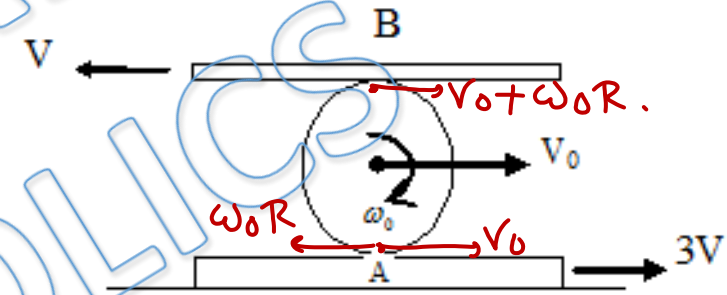

(a) Angular velocity of the disc is $\frac{2v}{r}$

(b) Linear velocity $v_0 = v$

(c) Angular velocity of the disc is $\frac{3v}{2r}$

(d) Both A & B

~~$$v_0 + \omega_0 R = -v$$~~

~~$$v_0 - \omega_0 R = 3v$$~~

$$2v_0 = 2v$$

$$v_0 = v$$

$$\omega_0 R = -2v$$

$$\omega_0 = -\frac{2v}{R}$$

Q.5) The disc of the radius R is confined to roll without slipping at A and B. If the plates having the velocities as shown, determine the angular velocity of disc

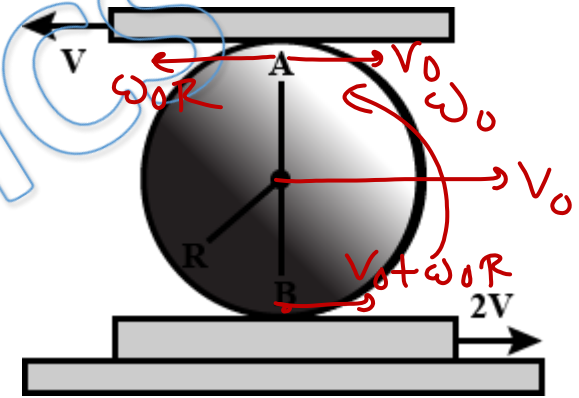

(a) $\frac{3v}{2r}$ clockwise

(b) $\frac{2v}{3r}$ clockwise

(c) $\frac{3v}{2r}$ anti-clockwise

(d) $\frac{2v}{3r}$ anti-clockwise

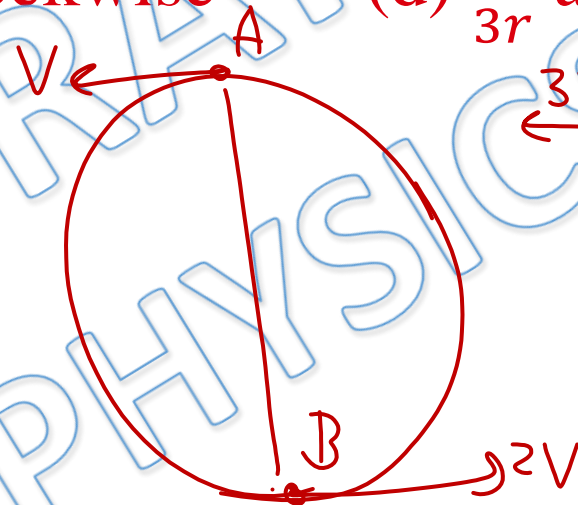

$$\omega_{rel} = \frac{3v}{2R}$$

$$v_0 + \omega_0 R = 2v$$

$$\omega_0 R - v_0 = v$$

$$2\omega_0 R = 3v$$

$$\omega_0 = \frac{3v}{2R}$$

Q.6) Instantaneous center of the rotation of disc is located at (o is centre of disc)

- (a) 0.2 m below O
- (b) 0.2 m above O
- (c) 0.6 m above O
- (d) 0.4 m below O

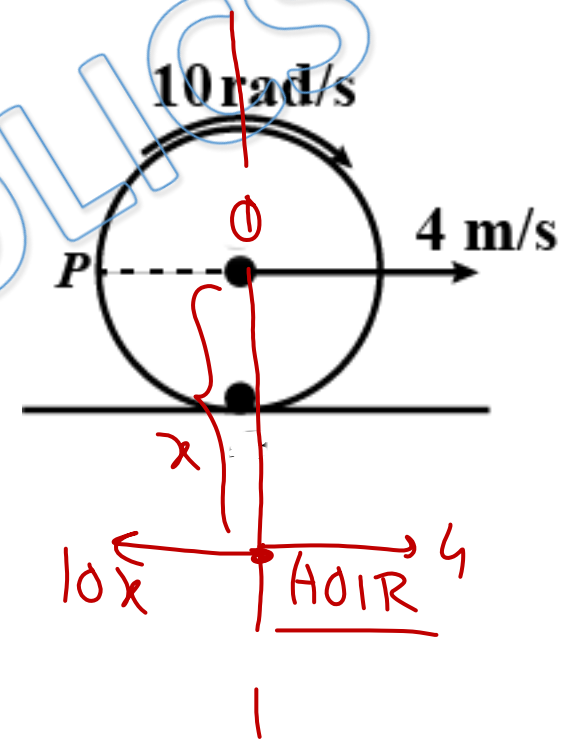

Q.7) A string of negligible thickness is wrapped several times around a cylinder kept on a rough horizontal surface. A man standing at a distance l from the cylinder holds one end of the string and pulls the cylinder towards him (figure). There is no slipping anywhere. The length of the string passed through the hand of the man while the cylinder reaches his hands is —

- (a) l
 (c) $3l$

- ~~(b) $2l$~~
 (d) $4l$

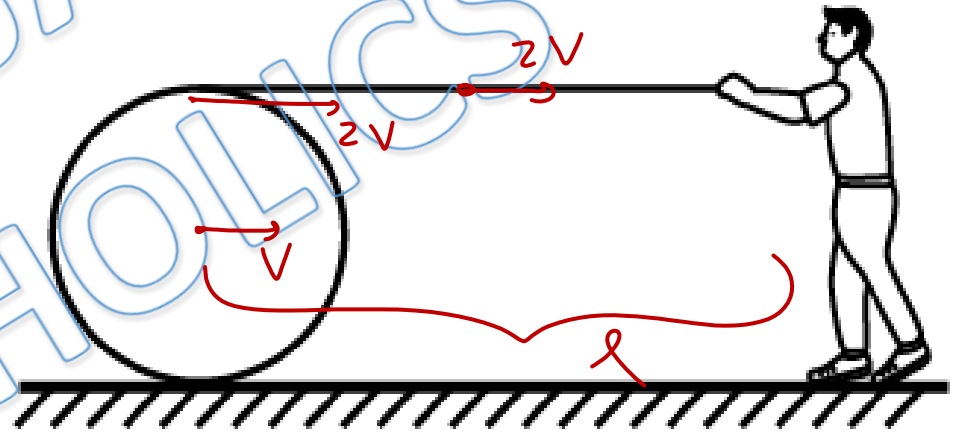

$$v_{\text{string}} = 2 v_{\text{cm}} = 2v$$

Q.8) Find the instantaneous axis of rotation of a rod of length " ℓ " when its end A moves with velocity $\vec{v} = v\hat{i}$ and the rod rotates with an angular velocity $\vec{\omega} = -\frac{v}{2\ell}\hat{k}$

(a) 2ℓ from A

(b) $\frac{2\ell}{3}$ from A

(c) $\frac{3\ell}{2}$ from A

(d) ℓ from A

$$\begin{aligned}\omega x &= v \\ x &= \frac{v}{\omega} \\ &= \underline{\underline{2\ell}}\end{aligned}$$

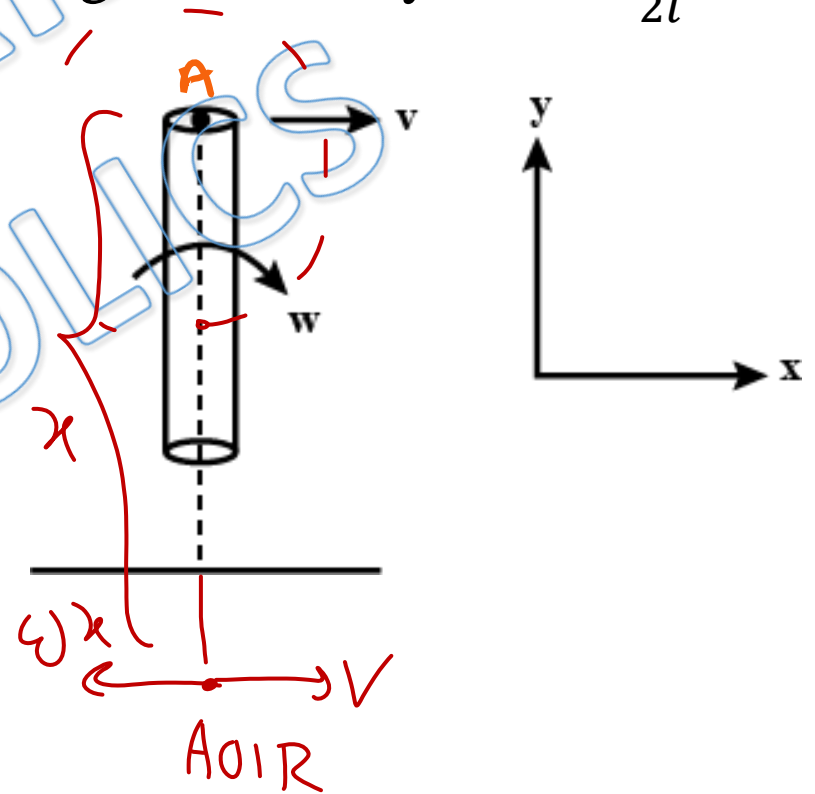

Q.9) A solid sphere is rolling on a surface as shown in figure, with a translational velocity $v \text{ m s}^{-1}$. If it is to climb the inclined surface continuing to roll without slipping, then minimum velocity for this to happen is

(a) $\sqrt{2gh}$

(b) $\sqrt{\frac{7}{5}gh}$

(c) $\sqrt{\frac{7}{2}gh}$

(d) $\sqrt{\frac{10}{7}gh}$

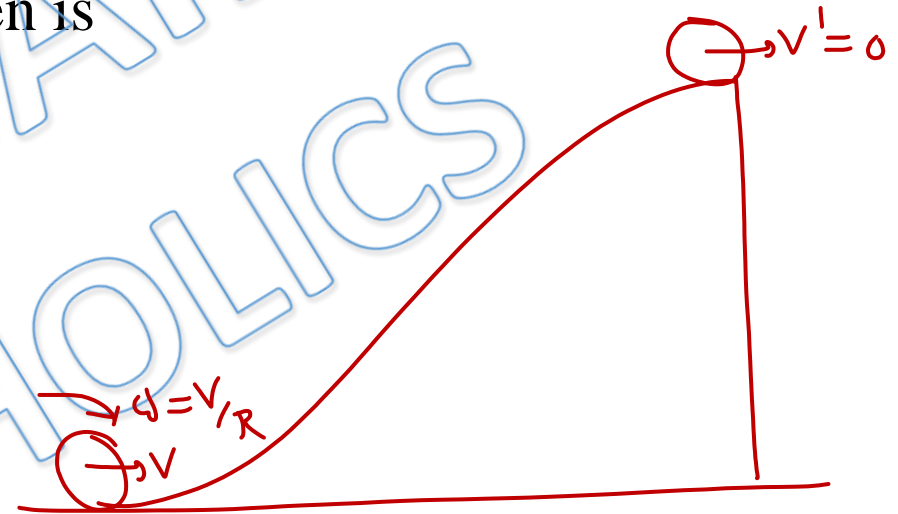

by COME

$$0 + \frac{1}{2}mv^2 + \frac{1}{2}\left(\frac{2}{5}mR^2\right)\left(\frac{v^2}{R^2}\right) = mgh$$

$$\frac{7}{10}mv^2 = mgh \Rightarrow v = \sqrt{\frac{10gh}{7}}$$

Q.10) A Disc is nonuniformly rolling on ground, acceleration of its bottommost point is

- (a) zero
- (b) Along velocity of centre
- ~~(c) In vertically upward direction~~
- (d) None of these

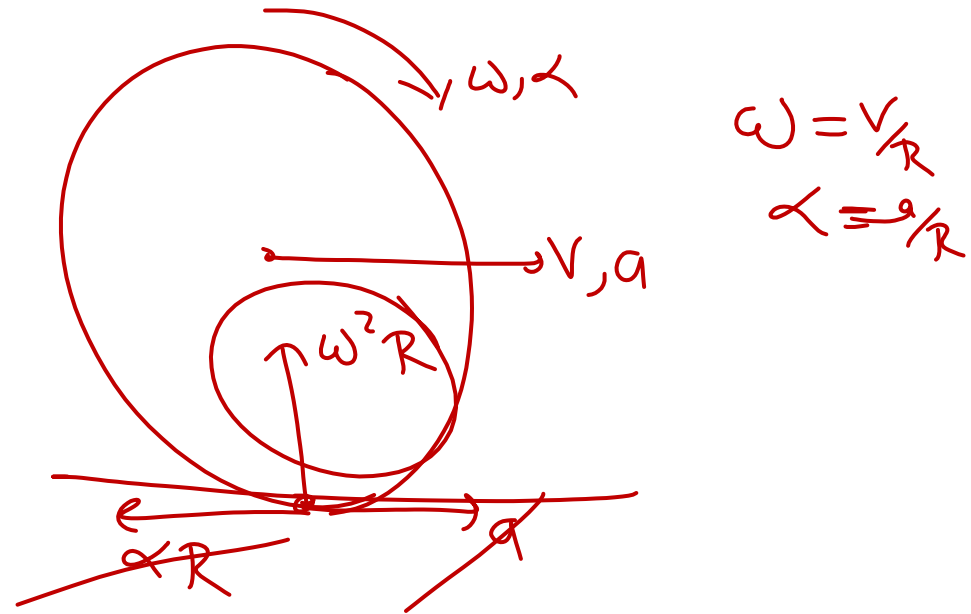

Q.11) A disc of radius 1 m is rolling on ground. Distance travelled by its centre in 7 rounds is

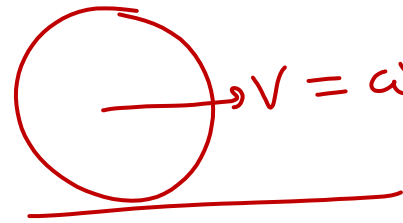
$$\Rightarrow \frac{dx}{dt} = R \frac{d\theta}{dt}$$

$$x = R\theta$$

In one round

$$x = 2\pi R$$

(a) 7 m

(b) 22 m

~~(c) 44 m~~

(d) It is not possible to find distance as velocity of centre of disc is not known.

$$= 44 \text{ m}$$

$$\begin{aligned} x &= 7 \times 2\pi R \\ &= 7 \times 2 \times \frac{22}{7} \times 1 \end{aligned}$$

Q.12) A man is pulling a string with speed v , which is wrapped on a spool. Speed of centre of spool is (if spool is rolling on ground)

$$\omega_0 = \frac{V_0}{2R}$$

(a) v

(b) $2v$

(c) ~~$4v/3$~~ $\frac{2v}{3}$

(d) $3v$

$$V = V_0 + \omega_0 R$$

$$V = V_0 + \frac{V_0}{2}$$

$$V = \frac{3V_0}{2}$$

$$V_0 = \frac{2V}{3}$$

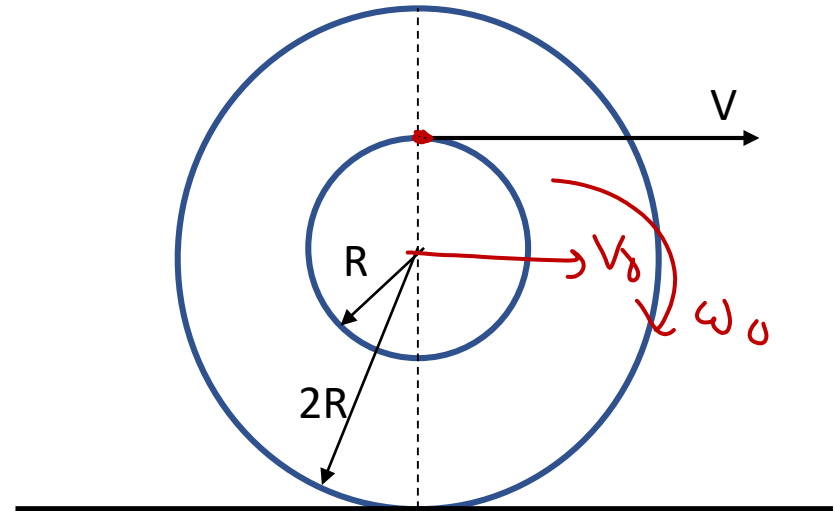

For Video Solution of this DPP, Click on below link

Video Solution
on Website:-

<https://physicsaholics.com/home/courseDetails/80>

Video Solution
on YouTube:-

<https://youtu.be/pDSah-0wgtk>

Written Solution
on Website:-

<https://physicsaholics.com/note/notesDetails/17>

 **SUBSCRIBE**



[@Physicsaholics](#)

[@Physicsaholics_prateek](#)

[@NEET_Physics](#)

[@IITJEE_Physics](#)

[physicsaholics.com](#)



CLICK

Chalo Niklo